

# Slot Diffusers

Type ESD

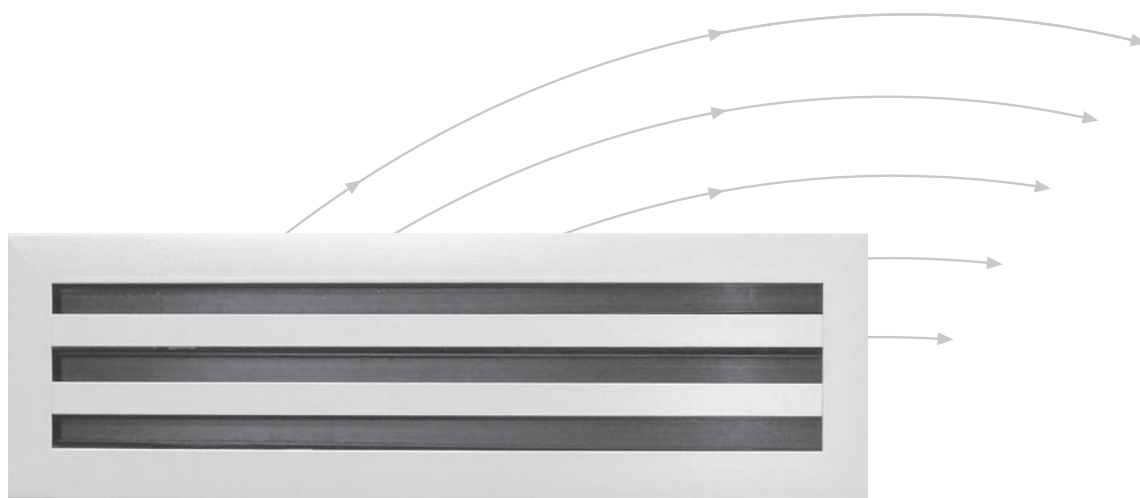

**TROX<sup>®</sup> TECHNIK**

TROX Malaysia Sdn. Bhd.  
20 Persiaran Bunga Tanjung 1  
Senawang Land Industrial Park  
70400 Seremban  
Negeri Sembilan Darul Khusus  
Malaysia

Telephone + 606-678 8188  
Telefax + 606-678 8288 / 388  
E-mail enquiry@troxmal.com.my  
www.troxapo.com

# Contents · Air Discharge Options · Description

Description	2	Nomenclature · Acoustic Data	6
Construction · Dimensions	3	Aerodynamic Data	8
Installation · Fixing details · Materials	4	Order Details	9
Installation Detail for Linear Slot Diffuser	5		

## Description

The Type 'ESD' Slot Diffuser can be provided with multiple slots, ranging from 1 to 8 slots. This slot diffuser can be utilised for either supply or return air application and, is suitable for cooling or heating mode with a temperature differential of 10 K.

Each air slot on the diffuser face is fitted with an air control blade that is manually adjusted to discharge the supply air either to the right or the left as shown below.

When there are more than 4 slots on the diffuser, it is recommended that to set only a maximum of 4 slots to discharge air in one direction and, the remaining slot(s) should discharge in the opposite direction.

**Figure 1:** Horizontal Discharge to the right.

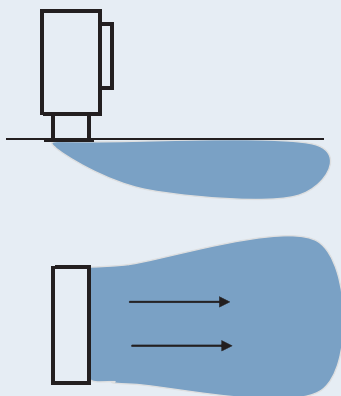

**Figure 2:** Horizontal Discharge to the left.

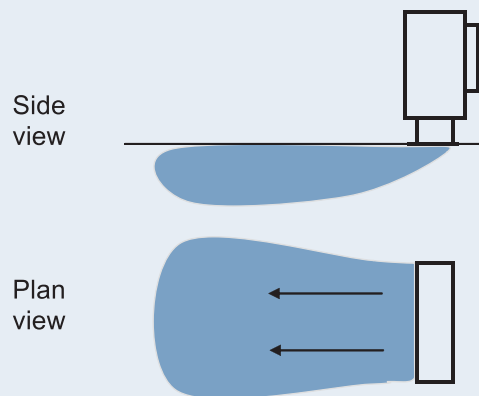

**Figure 3:** Horizontal Discharge to the left and right when there are more than four slots to the diffuser (Assumes even number of slots with equal amount of air discharging to each side).

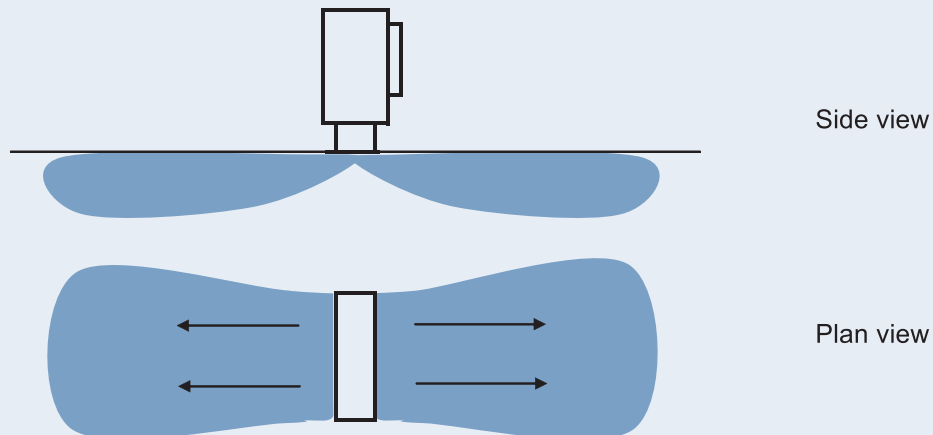

## Construction

The Type ESD Slot Diffuser is made from extruded aluminium sections with adjustable air control blade to each slot to direct the supply air to either side of the diffuser face.

As optional extras, this slot diffuser can be supplied with;

- Plenum box with circular inlet spigot(s) mounted to the rear of the diffuser or,
- Plenum box with volume control damper to each inlet spigot.

Refer to Table 1 below for further details.

The air control blades in the diffuser can be manually and individually set to discharge air horizontally to either left or right direction, as shown on page 2.

**Table 1: Number and size of Inlet Spigot Connections**

Length of Slot Diffuser, L1	No. of Inlet Spigot and Spigot Diameter, Ø D (mm)							
	ESD-1	ESD-2	ESD-3	ESD-4	ESD-5	ESD-6	ESD-7	ESD-8
600	1 x 123 Ø	1 x 148 Ø	1 x 198 Ø	1 x 248 Ø				
900								
1200								
1500								
2000	2 x 123Ø	2 x 148 Ø	2 x 198 Ø	2 x 248 Ø				

**Note:** When there are more than 4 slots to the diffuser, only a maximum of FOUR slots should be used to discharge air in any one direction and the remaining slot(s) should discharge in the opposite direction.

**Table 2: Dimensions**

No. of slots "n"	E	H1	H2	H3	K	P
1	38	158	204	127.5	100	77
2	76	183	229	140	138	115
3	114	200	246	148.5	176	153
4	152	233	279	165	214	192
5	190	283	329	190	235	230
6	228				273	268
7	266				312	306
8	304				350	344

**Figure 4: Type ESD-1 .... 8 – AK – M**

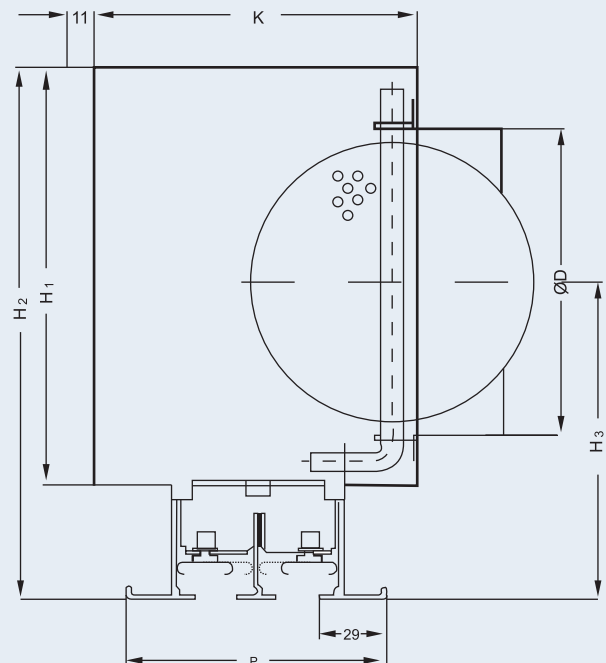

**Figure 5: Type ESD-1 .... 8**

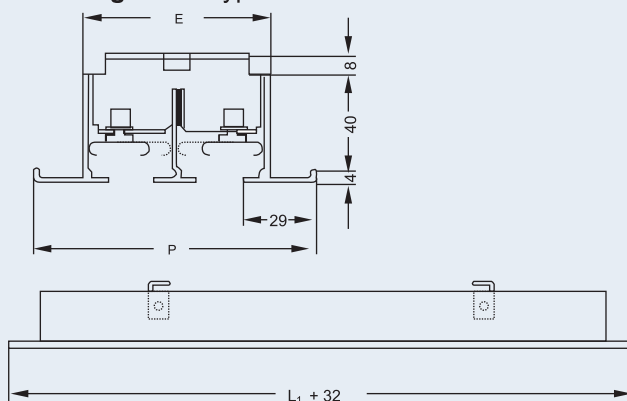

# Installation · Fixing Details · Materials

## Installation · Fixing Details

This slot diffuser is designed to be installed to suspended ceiling. It is also suitable to be used as a linear slot diffuser. Please refer to page 5 of this catalogue for further detail.

Support brackets will be provided to the plenum box to allow the plenum box and the diffuser, to be hung from the ceiling with drop rods fitted to structural members in the ceiling by others.

## Materials

The face of the diffuser and the air control blades are made from extruded aluminum sections. The face will be powder coated in matt white to RAL 9010 and, the air control blades will be in black to RAL 9005.

**Figure 6:** Installation of Slot Diffuser

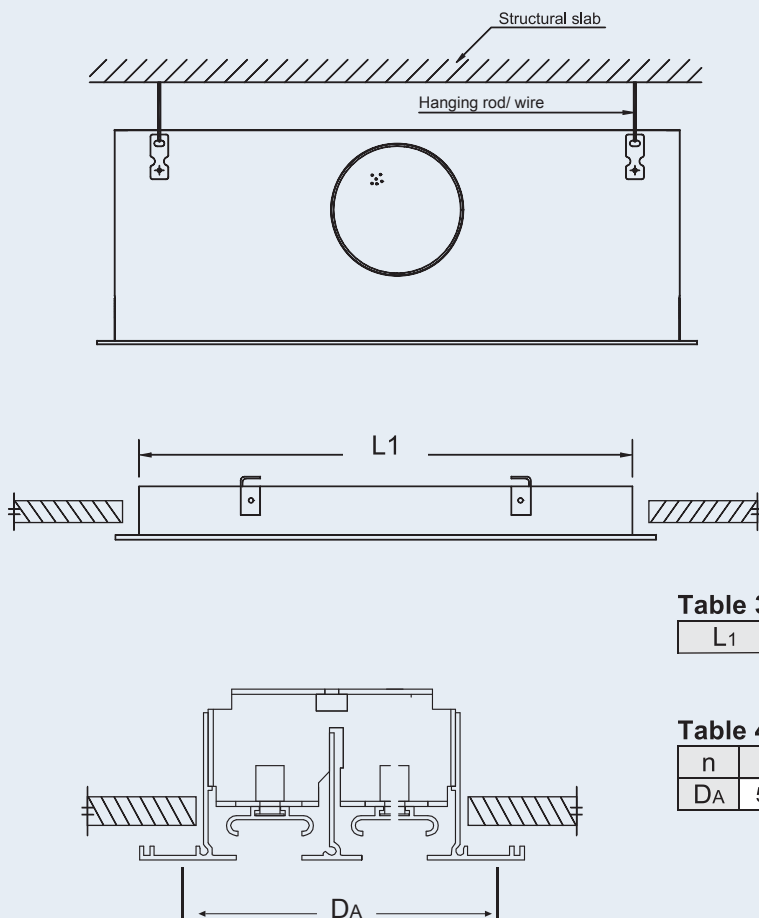

**Table 3:** Standard Nominal Length,  $L_1$

$L_1$	600	900	1200	1500	2000
-------	-----	-----	------	------	------

**Table 4:** Nominal Width for Slot Diffuser,  $D_A$

n	1	2	3	4	5	6	7	8
$D_A$	50	88	126	164	202	240	279	317

# Installation Detail for Linear Slot Diffuser

## Detail For Linear Slot Sections

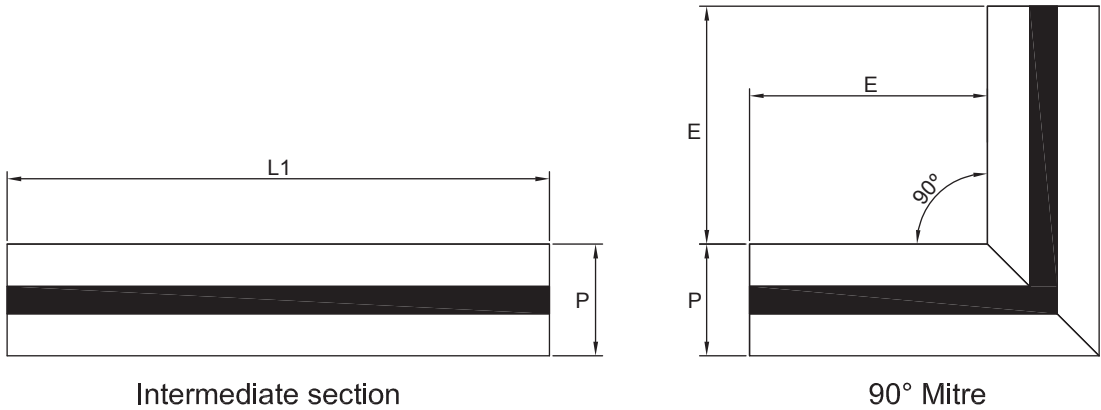
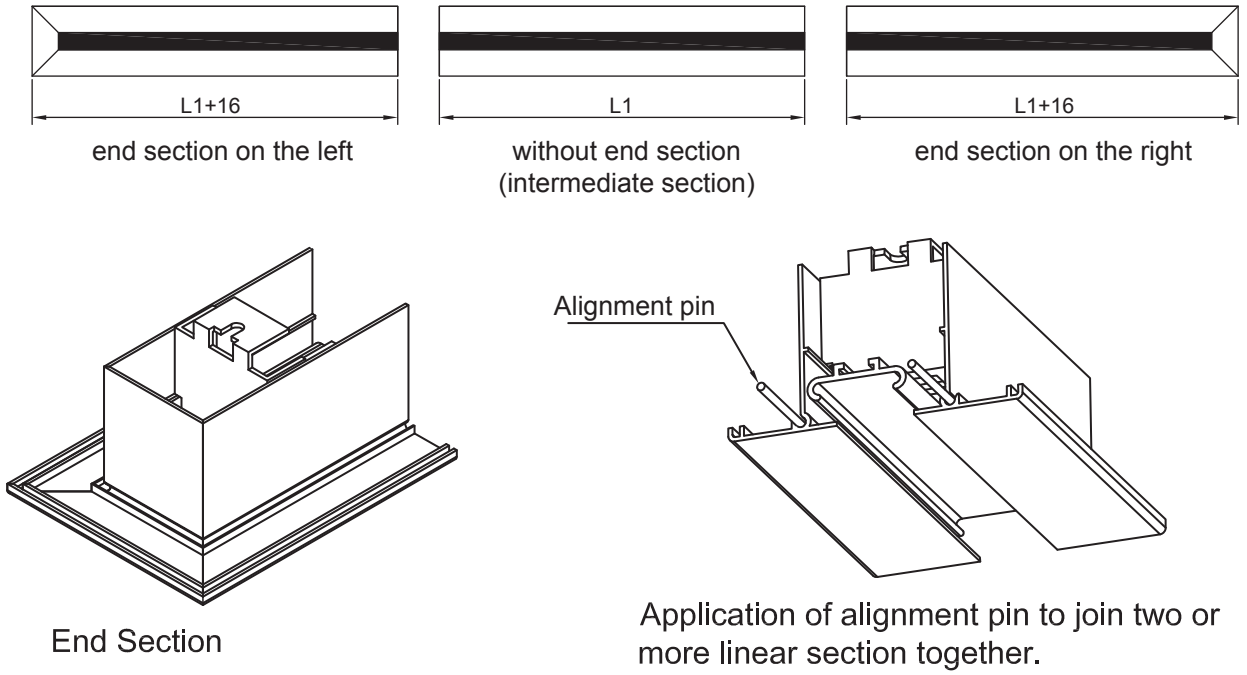

$L1$  : Standard Length of 600, 900, 1200, 1500, 1800, & 2100

**Figure 7**  
Joining linear section

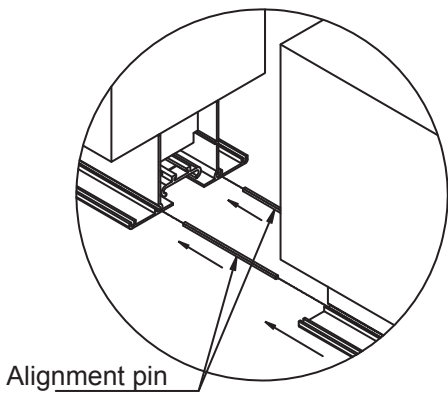

**Figure 8**  
Installing the diffuser face

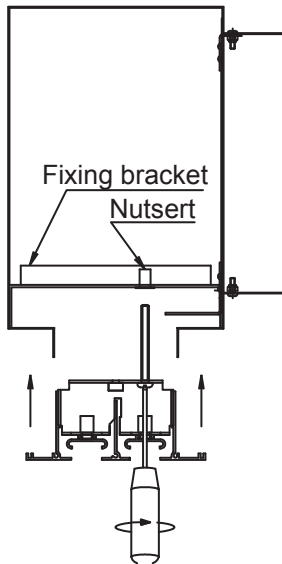

**Figure 9**  
Damper adjustment

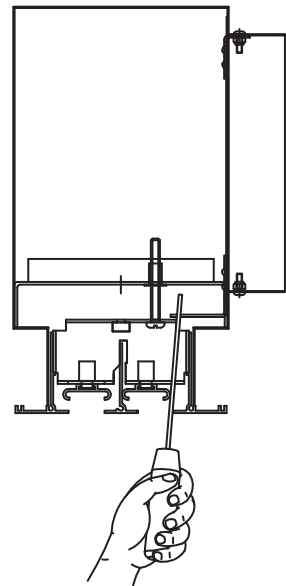

# Nomenclature · Acoustic Data

**NOTE:** The noise and pressure drop data derived from the graphs below and on page 6 is meant for the slot diffusers alone. The appropriate correction factors should be applied to the noise and pressure drop data if plenum boxes are required. Refer to Tables 5 and 6 for the correction factors.

**Graph1: ESD-1 ... 8/600**  
Noise criteria and pressure drop

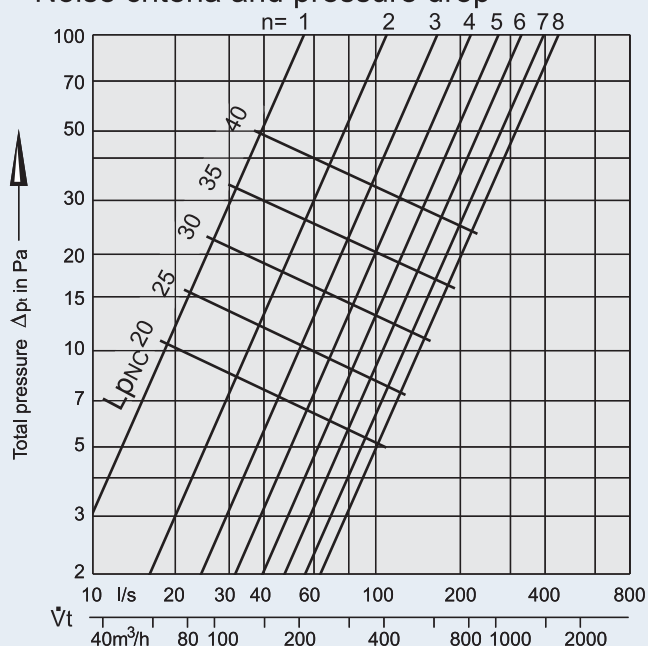

**Graph2: ESD-1 ... 8/900**  
Noise criteria and pressure drop

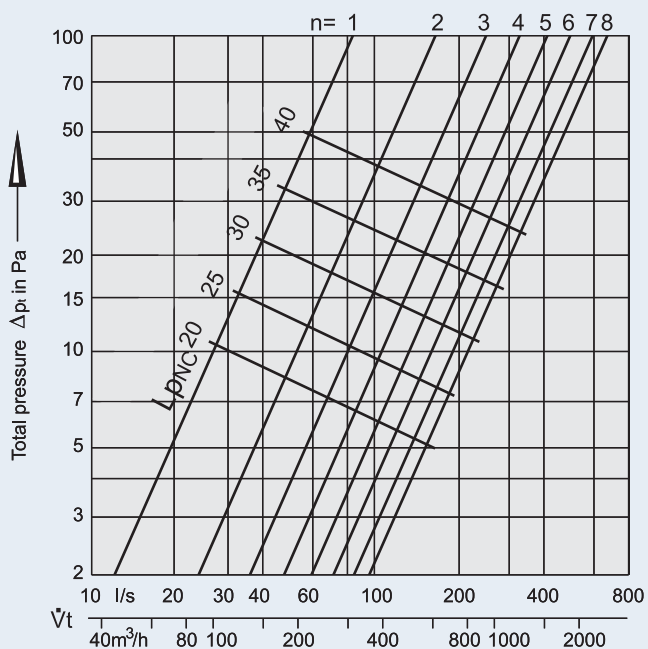

**Table 5:** Correction factors for Slot Diffuser with plenum boxes.

D	No. of slots 'n'	L1 = 600 mm		L1 = 900 mm	
		$\Delta p_t$	$\Delta p_p$	$\Delta p_t$	$\Delta p_p$
123	1	x 1.5	+ 0.0	x 1.8	+ 2.5
148	2	x 1.8	+ 1.5	x 2.2	+ 5.0
	3	x 2.2	+ 5.0	x 3.2	+ 9.0
198	4	x 1.9	+ 2.5	x 2.5	+ 6.0
248	5	x 1.7	+ 0.5	x 2.1	+ 4.0
	6	x 1.8	+ 2.0	x 2.4	+ 6.0
	7	x 2.0	+ 3.5	x 2.7	+ 7.0
	8	x 2.2	+ 5.0	x 3.1	+ 8.5

## Nomenclature

$\dot{V}$	l/s/m	Volume flow per metre length.
$\dot{V}$	m <sup>3</sup> /h/m	Volume flow per metre length.
$\dot{V}_t$	l/s	Total volume flow.
$\dot{V}_t$	m <sup>3</sup> /h	Total volume flow.
L	m	Throw.
$v_t$	m/s	Terminal velocity.
$\Delta t_z$	K	Temperature difference between supply air and room temperature.
$\Delta t_L$	K	Temperature difference between core and room temperature at distance, L.
$\Delta p_t$	Pa	Total pressure drop
$L_{pNC}$		Noise Criteria rating with 8 dB room attenuation.
$\Delta p_p$	dB	Difference in sound pressure level.

**Table 6:** Correction factors for Slot Diffuser with plenum boxes.

D	No. of slots 'n'	L1=1200 mm		L1=1500 mm		L1=2000 mm	
		$\Delta p_t$	$\Delta p_p$	$\Delta p_t$	$\Delta p_p$	$\Delta p_t$	$\Delta p_p$
123	1	x 2.2	+ 5.0	x 2.6	+ 7.0	x 1.9	+ 3.0
148	2	x 2.9	+ 8.0	x 3.7	+10.0	x 2.4	+6.0
	3	x 4.7	+11.5	x 6.8	+13.5	x 3.7	+10.0
198	4	x 3.2	+ 9.0	x 4.2	+11.0	x 2.7	+7.0
248	5	x 2.6	+ 7.0	x 3.2	+ 9.0	x 2.2	+ 5.0
	6	x 3.1	+ 8.5	x 4.0	+10.5	x 2.6	+7.0
	7	x 3.7	+10.0	x 5.0	+12.0	x 3.0	+8.0
	8	x 4.4	+11.0	x 6.2	+13.0	x 3.5	+9.5

**NOTE:** The noise and pressure drop data derived from the graphs below are meant for the slot diffusers alone. The appropriate correction factors should be applied to the noise and pressure drop data for each diffuser unit size if plenum boxes are required. Refer to Tables 5 and 6 for the appropriate correction factors.

**Graph 3:** ESD-1 ... 8/1200  
Noise criteria and pressure drop

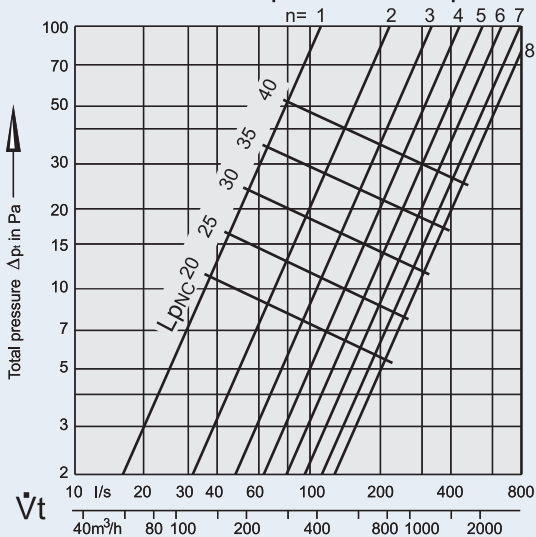

**Graph 5:** ESD-1 ... 8/2000  
Noise criteria and pressure drop

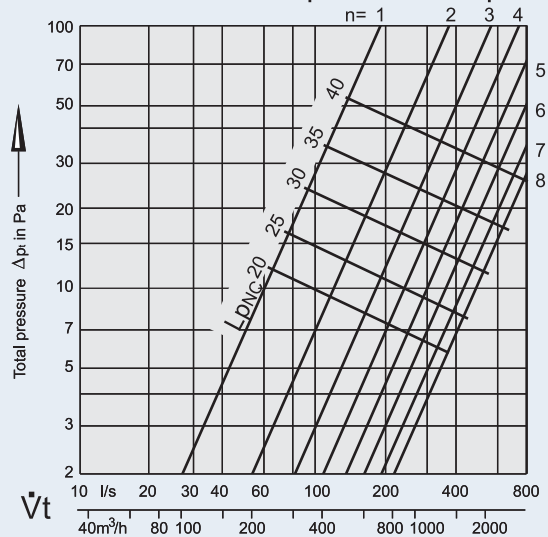

**Graph 4:** ESD-1 ... 8/1500  
Noise criteria and pressure drop

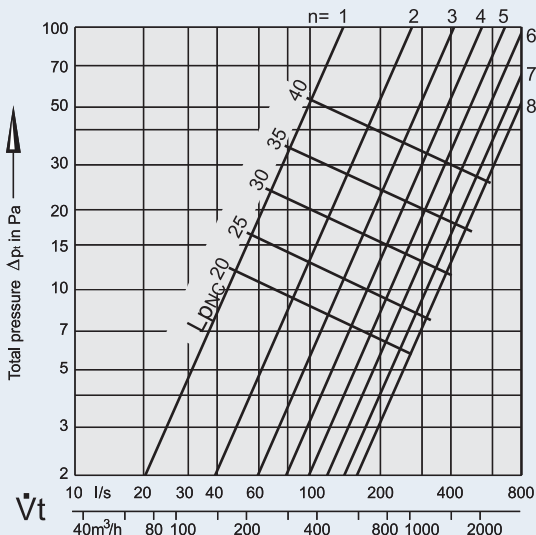

# Aerodynamic Data

## Selection Example

Data given:

$\dot{V}_t = 75 \text{ l/s}$ ; throw,  $L = 5 \text{ m}$  and  $\Delta t_z = -6 \text{ K}$ .

Slot diffuser: Type ESD - 3 - AK / 1500

$\dot{V} = 75 \text{ l/s} / 1.5 \text{ m}$   
 $= 50 \text{ l/s/m}$ .

From Graph 6, terminal velocity,  $v_L$  is 0.45 m/s.

Graph 7, the temperature quotient is 0.22.

Hence,  $\Delta t_L = 0.22 \times -6$

$\Delta t_L = -1.32 \text{ K}$

From Graph 4;

$L_{pNC}$  is NC15 and  $\Delta p_t = 3.5 \text{ Pa}$

From Table 6, the correction factors to be applied to noise level and pressure drop are as follow;

$L_{pNC} = 15 + 13.5 = \text{NC } 28$ .

$\Delta p_t = 3.5 \times 6.8 = 24 \text{ Pa}$ .

**Graph 6: Terminal Velocity and Throw**

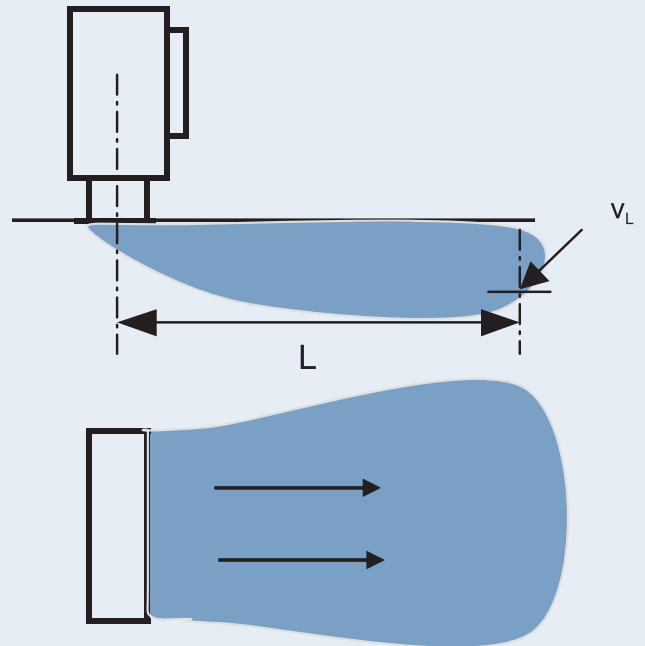
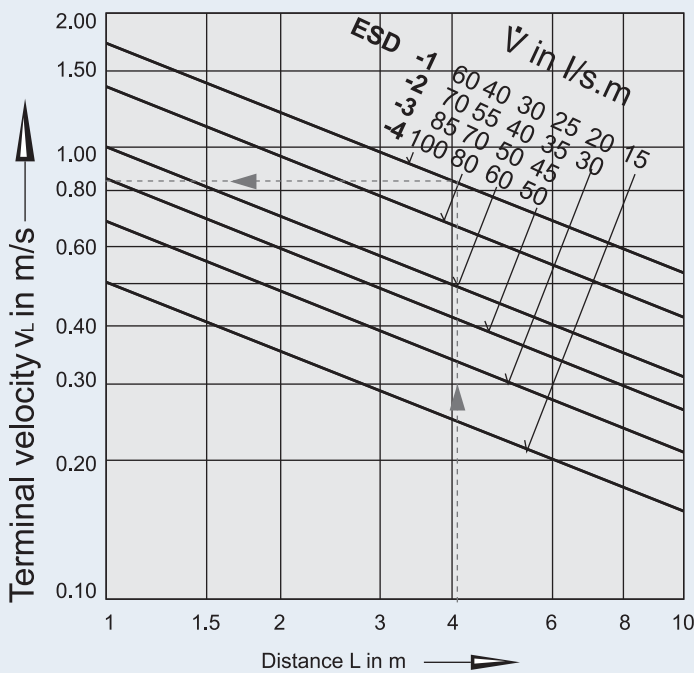

**Graph 7: Temperature Quotient**

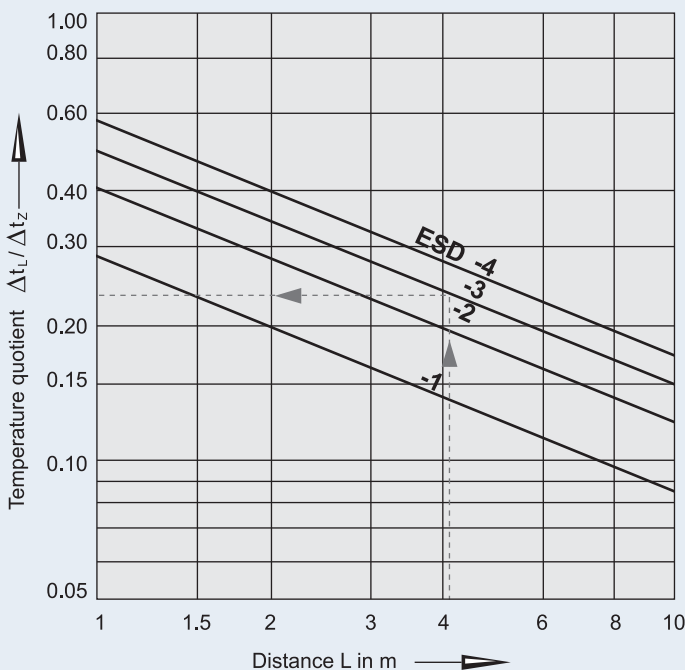

## Order Code

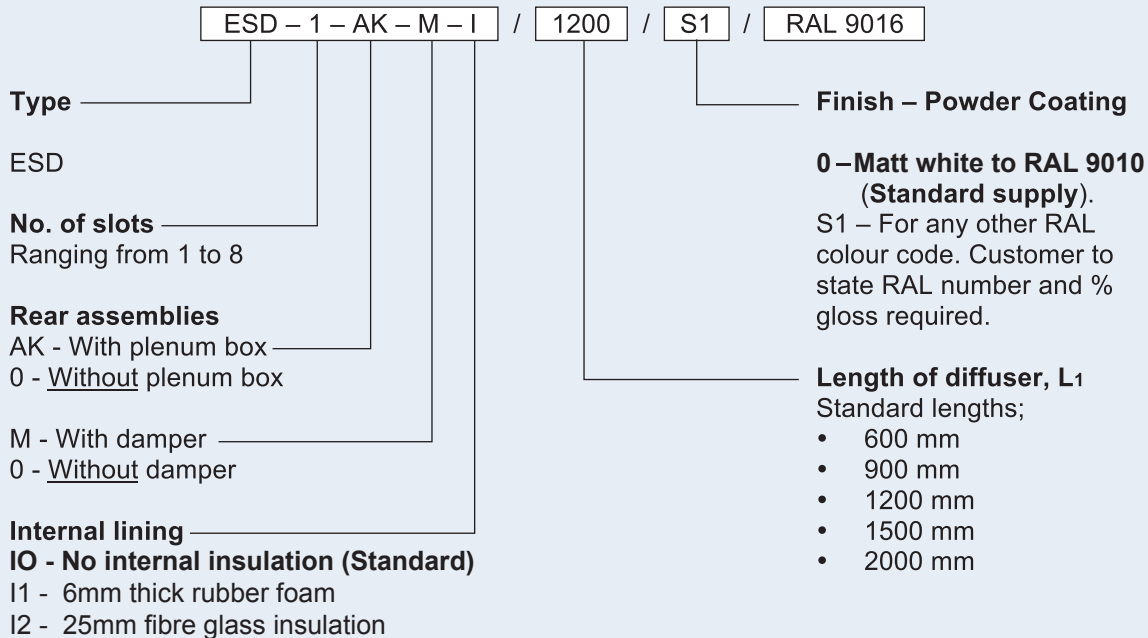

## General Specification

This Type ESD slot diffuser is made from extruded aluminium sections with multiple slots ranging from 1 to 8 slots. Each slot is fitted with an adjustable air control blade to direct the supply air either to the left or the right of the slot diffuser.

The face of the diffuser will be powder coated in matt white to RAL 9010 as standard supply and the air control blades will be in black to RAL 9005.

If required, the plenum box can be supplied with this slot diffuser. The plenum is made from galvanized sheet steel. As optional extras, the following options can be provided with the plenum box;

- a. Internal Thermal Insulation:  
Two available options for fire retardant thermal insulation materials are either;
  - 6 mm thk. rubber foam lining
  - 25 mm thk. fibre glass lining
- b. Volume control damper that is adjustable from the diffuser face and is

designed to minimize regenerated noise.

The plenum box will be fitted with supporting brackets to allow the plenum box to be hung from the ceiling together with the slot diffuser.

## Caution

It should be noted that when there are more than 4 slots on this diffuser, it is recommended that no more than 4 slots should be directed to discharge air the same direction. The remaining slot(s) should then be set to discharge air in the opposite direction as shown in Figure 3 on page 2.

## Order Example

Make: TROX  
Type: ESD-4-AK-0-I0/0  
Quantity: 36 nos.

