

LABCONTROL VAV controller

For laboratories
Type TVLK

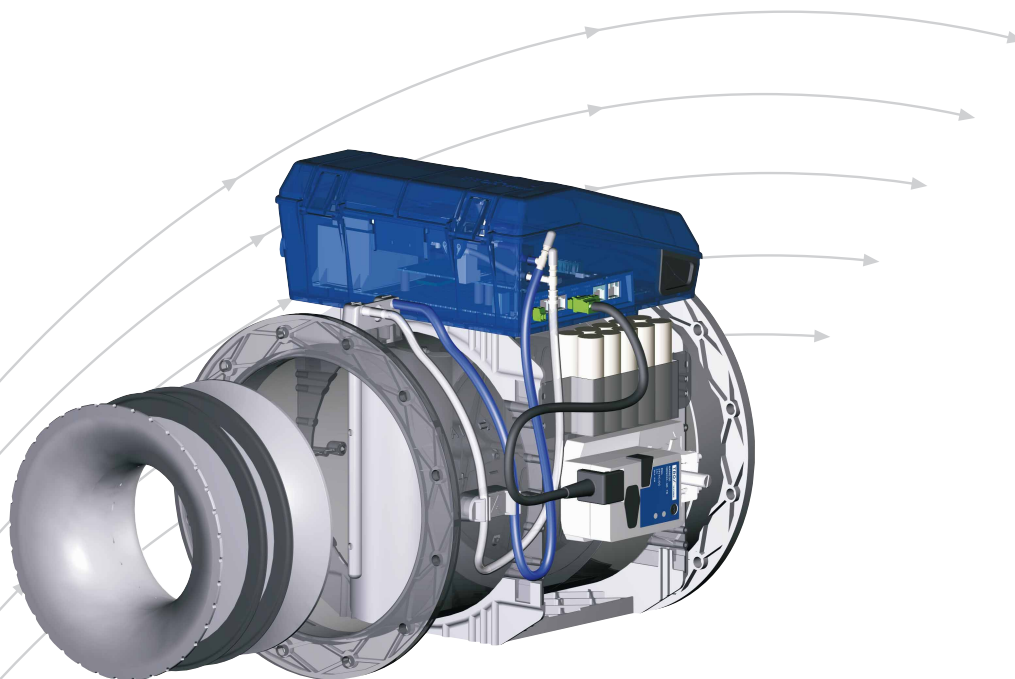

TROX[®] TECHNIK

TROX GmbH
Heinrich-Trox-Platz
D-47504 Neukirchen-Vluyn

Telephone +49(0)28 45/202-0
Telefax +49(0)28 45/202-265
E-Mail trox@trox.de
www.troxtechnik.com

Contents · Description

Description	2	Quick selection of TVLK with venturi nozzle	7
Construction · Dimensions	3	Air-regenerated noise	8
Functional description	4	Case-radiated noise	9
Nomenclature · Quick selection of TVLK with differential pressure flow screen or flow grid	6	Order details	10

TVLK with differential pressure flow screen



TVLK with venturi nozzle



The VAV controller type TVLK controls the flow rate in ventilation systems for laboratories and industrial production sites. The controller casing and all parts that come into contact with the air flow are made of plastic. In this way, the controller is especially suited for the extract air from fume cupboards, which often contains aggressive substances.

The VAV controller contains an averaging differential pressure sensor (differential pressure flow screen, flow grid or venturi nozzle) for the measurement of the flow rate and a control damper.

- Differential pressure flow screen or flow grid
The sensor tubes can be removed, which enables an easy, effective check for dirt. The shape of the sensor prevents incorrect re-assembly.
- Venturi nozzle
The venturi nozzle is removable for inspection and cleaning. The flow rate measurement using a venturi nozzle generates low sound power levels and minimum differential pressures.

The mechanical and electronic control components are factory fitted to form the controls package. Every controller is set up to the required flow rates and is subjected to an aerodynamic function test.

Special characteristics

- All components coming into contact with the extract air are made of chemically resistant and flame-retardant polypropylene, the control damper seal is made of thermoplastic elastomer (TPE); no metal parts in the air flow.
- Length of the VAV controller only 392 mm (with flange 400 mm)
- Very close control accuracy for the flow rate settings, even in case of unfavourable aerodynamic configuration of ductwork
- With either differential pressure flow screen, flow grid or venturi nozzle
- Flanges can be attached without welding work
- Factory set up of flow rate. This includes aerodynamic function test of each controller using a dedicated test rig
- Combination with plastic circular silencer type CAK for critical acoustic requirements

Further, current information on application, selection as well as control components available can be found on our website.

Also available on the internet is the on-line design programme "air terminal units" for the design and selection of our units.

Construction - Dimensions

Characteristics

- Electronic flow rate control
- Suitable for extract air with aggressive substances
- Flow rate range (depending on manufacturer and type of controller) approx. 8 : 1
- With either differential pressure flow screen, flow grid or venturi nozzle for flow rate measurement
- Very close control accuracy for the flow rate settings, no additional straight upstream duct length required
- Differential pressure range 80 to 1000 Pa
- Shut-off from duct work system, switch by others
- Control damper closed blade air leakage to EN 1751, class 3
- Factory set up of flow rate. This includes aerodynamic function test of each controller using a dedicated test rig. Data covering set up is given on a test label attached to each controller.
- Flow rate can be measured and subsequently reset on site
- The controllers are, in terms of their mechanical parts, maintenance-free
- Operating temperature range 10 to 50 °C

Construction features

- Compact construction
392 mm without flange
400 mm with flange
- Same connection diameter on both ends 250 mm
- Option with flange on both ends
- Casing air leakage complies with EN 1751, class B

Materials

- Casing and control damper blade in polypropylene (PPs), flame-retardant (V0) to UL 94
- Plain bearings made of polypropylene (PP)
- Control damper seal made of thermoplastic elastomer (TPE)
- Differential pressure sensor made of plastic (PP)

Additional silencer

- Suitable for TVLK
- Plastic circular silencer type CAK
- For dimensions and technical data, see Leaflet 6/5.1/EN/...

TVLK

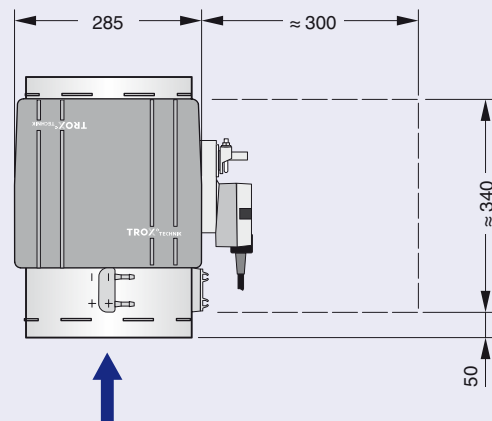
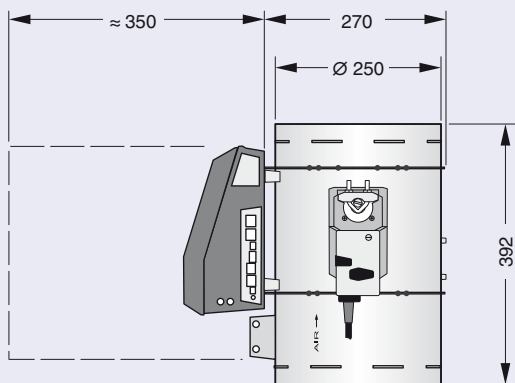

TVLK, flange construction

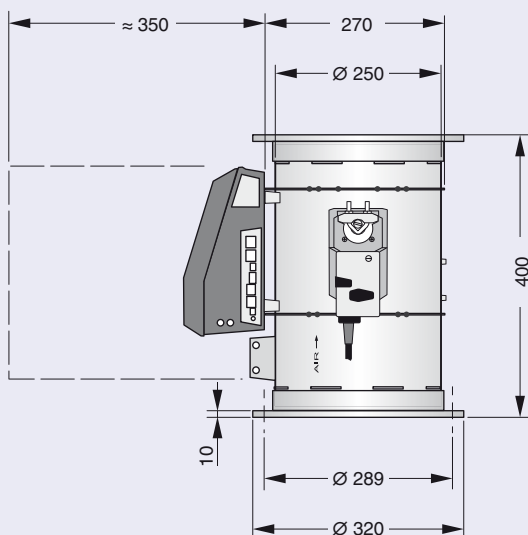

--- Keep clear to provide access to control components

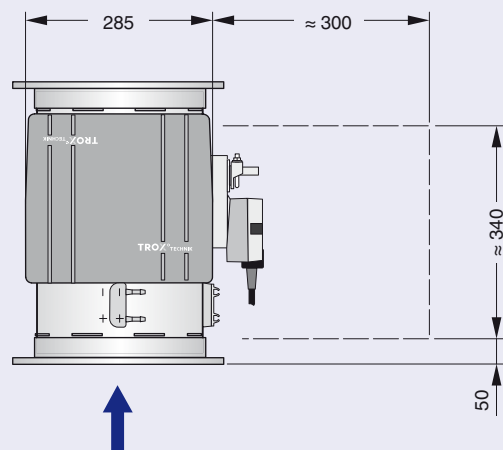

Functional description

Flow rate measurement

Measurement accuracy is of crucial importance for every form of control. The measurement equipment of an air terminal unit deserves special attention for this reason.

A sensor is necessary for the direct measurement of air flow, this is achieved by pressure measurement at several points distributed over the cross-section and provision of the resulting average value. The TROX differential pressure sensors are an optimum solution in terms of economics and product technology. These sensors deliver exact results for most room air conditioning applications based on normal upstream flow conditions.

Differential pressure flow screen or flow grid

The sensor tubes are removable, which enables an easy, effective check for dirt. The shape of the sensor prevents incorrect re-assembly.

Venturi nozzle

The flow rate measurement using a venturi nozzle generates low sound power levels and minimum differential pressures.

The nozzle is removable for inspection and cleaning.

Flow rate measurement

With differential pressure flow screen (250-100, 250-160)

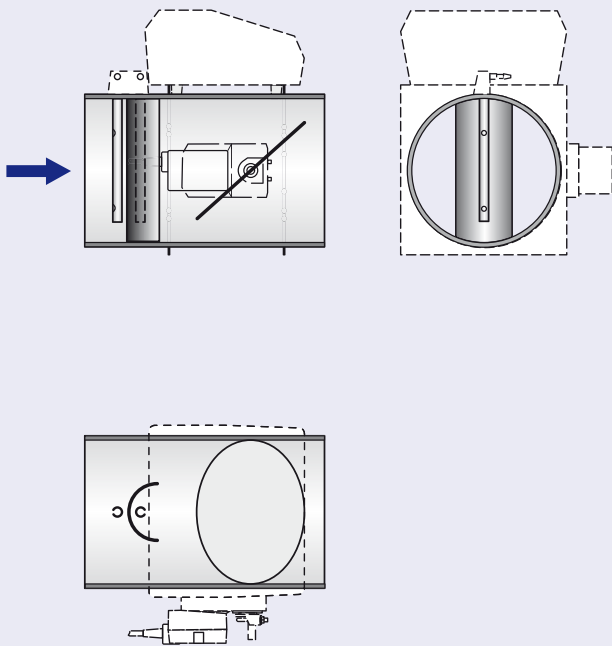

With venturi nozzle (250-D10, 250-D16)

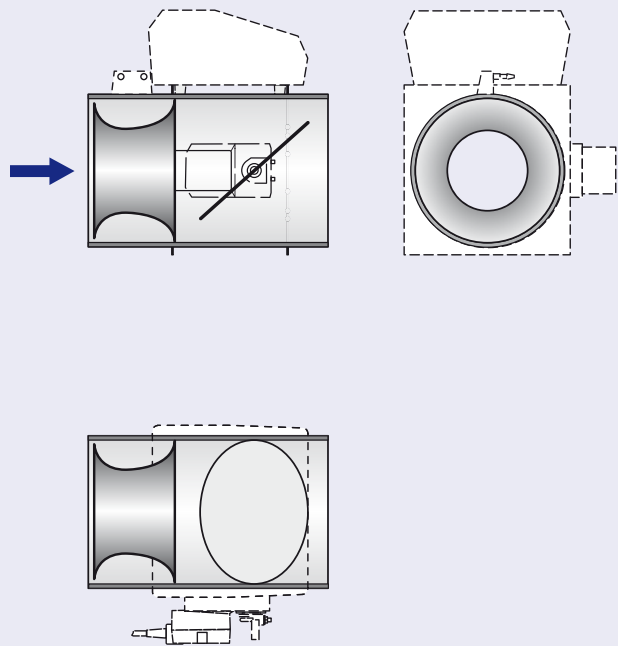

Flow rate control

The control of the flow rate takes place in a closed control loop, i.e. measurement – comparison – control.

A pressure transducer converts the pressure differential into an electrical signal, which is interpreted as the actual value by the controller. In most applications, the setpoint value comes from a room temperature controller.

The controller compares the actual value with the setpoint value and from the difference between these two adjusts the control signal to the damper actuator.

Fume cupboard control

The control of air loaded with aggressive media is the main area of application of the TVLK. For rapid sash movement a quick response control system is incorporated into the TVLK.

In this way, the ventilation requirements according to the European standards such as EN 14175 and the technical requirements of various communication systems for the room controllers are fulfilled.

Control diagram of the fume cupboard control system

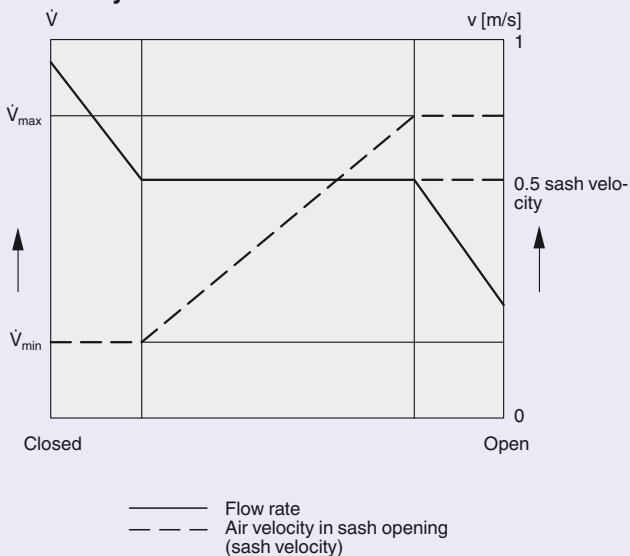

Legend

- ① VAV controller
- ② Flow rate controller
- ③ Differential pressure sensor
- ④ Flow screen
- ⑤ Diaphragm pressure transducer
- ⑥ Actuator
- ⑦ External setpoint setting possible (by others)
- ⑧ Sash velocity sensor or sash position sensor
- ⑨ Control unit

Flow rate control

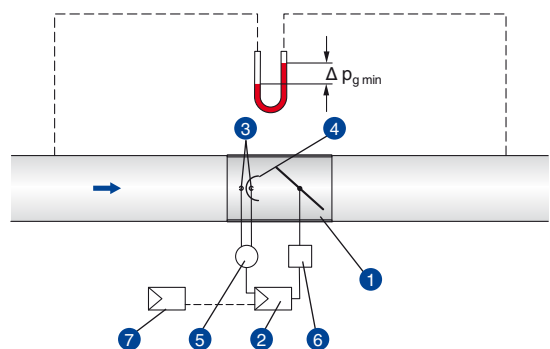

Fume cupboard control

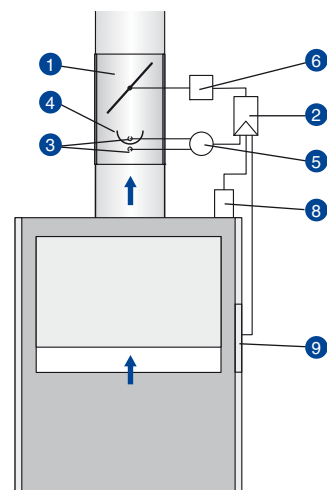

Definitions · Quick selection of TVLK

with differential pressure flow screen or flow grid

Nomenclature

f_m	in Hz:	Octave band centre frequency
L_W	in dB:	Sound power level of the air-regenerated noise in the room (low pressure) side ducting duct
L_{W2}	in dB:	Sound power level of the case-radiated noise
L_{pA}	in dB(A):	A-weighted sound pressure level of air-regenerated noise, system attenuation taken into account
L_{pA1}	in dB(A):	A-weighted sound pressure level of air-regenerated noise with CAK circular silencer, system attenuation taken into account
L_{pA2}	in dB(A):	A-weighted sound pressure level of case-radiated noise, system attenuation taken into account
\dot{V}	in l/s or m ³ /h:	Flow rate
$\Delta \dot{V}$	in ± %:	Flow rate tolerance from setpoint value
Δp_g	in Pa:	Total pressure differential
$\Delta p_{g \min}$	in Pa:	Minimum total pressure differential

All sound power levels are based on 1 pW, all sound pressure levels on 20 µPa.

All noise levels determined in a reverberation chamber. The sound power data was determined and corrected according to EN ISO 5135, February 1999.

System attenuation in dB/oct. according to VDI 2081 (taken into account in the quick selection table)

f_m in Hz	63	125	250	500	1000	2000	4000	8000
Duct bend attenuation	0	0	1	2	3	3	3	3
End reflection	10	5	2	0	0	0	0	0
Room attenuation	5	5	5	5	5	5	5	5

Quick selection sound pressure level in dB(A)

Differential pressure flow screen or flow grid	\dot{V}		$\Delta p_{g \min}$	$\Delta \dot{V}$	$\Delta p_g = 200 \text{ Pa}$				$\Delta p_g = 500 \text{ Pa}$				
					Air-regenerated noise			Case-radiated noise ¹⁾	Air-regenerated noise			Case-radiated noise ¹⁾	
					Without Silencer	With CAK Length in mm			Without Silencer	With CAK Length in mm			
						L_{pA}	500 L_{pA1}			1000 L_{pA1}	L_{pA}		500 L_{pA1}
Control system: TROX LABCONTROL with TROX controllers TCU-LON II, TCU II (TMx, ELAB)													
100	55	198	< 10	10	44	38	34	28	55	49	45	38	
	140	504	13	7	50	42	38	36	60	54	50	45	
	220	792	31	6	51	43	39	39	61	54	50	48	
	360	1296	82	5	52	43	39	44	62	55	50	52	
160	30	108	< 10	10	42	37	33	25	54	49	45	37	
	80	288	21	7	46	40	36	32	58	52	49	43	
	120	432	48	6	48	41	38	35	60	54	50	46	
	195	702	127	5	49	42	38	39	61	54	50	50	
Control system: TROX controllers (e.g. BB3, BPx)													
100	65	234	< 10	10	45	38	34	29	56	50	46	39	
	180	648	21	7	50	43	38	38	61	54	50	47	
	290	1044	53	6	51	43	39	42	61	54	50	51	
	360	1296	82	5	52	43	39	44	62	55	50	52	
160	35	126	< 10	10	43	37	33	26	55	50	46	38	
	100	360	34	7	47	41	37	34	59	53	49	44	
	160	576	85	6	49	42	38	37	61	54	50	48	
	195	702	127	5	49	42	38	39	61	54	50	50	

1) 4 dB/octave ceiling reduction and 5 dB/octave fume hood cladding have been allowed for in the calculation of case-radiated noise. For acoustic data for differential pressure up to 1000 Pa, see on-line design programme "Air terminal units".

Quick selection of TVLK

with venturi nozzle

System attenuation in dB/oct. according to VDI 2081 (taken into account in the quick selection table)

f_m in Hz	63	125	250	500	1000	2000	4000	8000
Duct bend attenuation	0	0	1	2	3	3	3	3
End reflection	10	5	2	0	0	0	0	0
Room attenuation	5	5	5	5	5	5	5	5

Quick selection sound pressure level in dB(A)

Venturi nozzle	\dot{V}		$\Delta p_{g \min}$	$\Delta \dot{V}$	$\Delta p_g = 200 \text{ Pa}$				$\Delta p_g = 500 \text{ Pa}$			
					Air-regenerated noise			Case-radiated noise ¹⁾	Air-regenerated noise			Case-radiated noise ¹⁾
					Without Silencer	With CAK Length in mm			Without Silencer	With CAK Length in mm		
	l/s	m ³ /h			L_{pA}	L_{pA1} 500	L_{pA1} 1000	L_{pA2}	L_{pA}	L_{pA1} 500	L_{pA1} 1000	L_{pA2}
Control system: TROX LABCONTROL with TROX controllers TCU-LON II, TCU II (TMx, ELAB)												
D10	55	198	< 10	10	38	31	27	25	44	37	33	32
	140	504	16	7	44	37	33	32	51	43	39	39
	220	792	19	6	46	38	34	36	52	44	41	43
	360	1296	50	5	47	39	35	40	54	46	42	47
D16	30	108	< 10	10	37	32	28	24	48	43	39	34
	80	288	12	7	43	38	34	30	54	49	45	40
	120	432	27	6	46	40	37	33	56	51	48	43
	195	702	70	5	47	42	38	37	58	52	49	46
Control system: TROX controllers (e.g. BB3, BPx)												
D10	65	234	< 10	10	39	32	28	26	45	38	34	33
	180	648	< 10	7	45	37	33	34	51	44	40	41
	290	1044	32	6	46	38	34	38	53	45	41	45
	360	1296	50	5	47	39	35	40	54	46	42	47
D16	35	126	< 10	10	38	33	29	25	49	44	40	35
	100	360	19	7	45	39	36	32	55	50	46	42
	160	576	47	6	47	41	38	35	57	52	49	45
	195	702	70	5	47	42	38	37	58	52	49	46

1) 4 dB/octave ceiling reduction and 5 dB/octave fume hood cladding have been allowed for in the calculation of case-radiated noise. For acoustic data for differential pressure up to 1000 Pa, see on-line design programme "Air terminal units".

Air-regenerated noise

Example

Given: $\dot{V}_{\max} = 140 \text{ l/s}$ or $504 \text{ m}^3/\text{h}$
 $\Delta p_g = 200 \text{ Pa}$
 Required sound pressure level in the room 50 dB(A)
 TVLK 250-100

Calculation procedure for air-regenerated noise

f_m	63	125	250	500	1000	2000	4000	8000
L_w	58	60	60	56	50	45	41	35
Duct bend/ fume cupboard	0	0	1	2	3	3	3	3
End reflection	10	5	2	0	0	0	0	0
Sound power level to room	48	55	57	54	47	42	38	32
Room attenuation	5	5	4	4	3	3	3	3
A-weighting	-26	-16	-9	-3	0	1	1	-1
Corrected level	17	34	44	47	44	40	36	28

Calculation procedure

Quick selection:
 TVLK 250-100

Air-regenerated noise $L_{pA} = 50 \text{ dB(A)}$
 Case-radiated noise $L_{pA2} = 36 \text{ dB(A)}$

Sound pressure level in room = 50 dB(A)

Sound pressure level of air-regenerated noise $L_{pA} = 51 \text{ dB(A)}$

Air-regenerated noise																		
Differential pressure sensor	\dot{V}		$\Delta p_g = 200 \text{ Pa}$								$\Delta p_g = 500 \text{ Pa}$							
			L_w in dB								L_w in dB							
			f_m in Hz								f_m in Hz							
			63	125	250	500	1000	2000	4000	8000	63	125	250	500	1000	2000	4000	8000
Differential pressure flow screen or flow grid																		
100	55	198	49	53	57	51	41	37	31	25	56	64	68	62	50	45	41	35
	65	234	50	54	57	52	43	38	33	27	58	65	69	63	51	46	43	37
	140	504	58	60	60	56	50	45	41	35	65	71	72	67	58	53	51	45
	180	648	61	62	61	58	52	47	44	38	68	73	73	69	60	56	54	48
	220	792	63	63	62	59	54	49	46	40	70	74	74	70	62	57	56	50
	290	1044	65	65	63	60	56	52	49	43	73	76	75	71	64	60	59	53
360	1296	68	67	64	62	58	54	51	45	75	78	76	72	66	62	61	55	
160	30	108	46	54	56	47	37	34	28	20	52	66	69	59	46	45	39	33
	35	126	47	55	56	48	38	36	30	21	53	66	69	60	48	46	41	35
	80	288	54	60	59	51	44	42	39	30	60	71	72	63	54	53	50	44
	100	360	56	61	59	52	46	44	41	33	62	72	72	64	55	55	52	46
	120	432	58	62	60	52	47	46	43	34	64	73	73	65	57	56	54	48
	160	576	61	63	61	54	49	48	46	38	67	74	73	66	59	58	58	51
195	702	62	64	61	54	51	50	49	40	68	75	74	67	60	60	60	53	
Venturi nozzle																		
D10	55	198	48	50	49	43	39	36	32	26	51	58	54	48	44	42	43	33
	65	234	49	51	50	45	40	37	33	27	52	59	55	50	45	43	45	35
	140	504	56	57	54	50	45	43	40	34	59	65	59	55	49	49	52	41
	180	648	58	59	55	52	46	45	42	36	61	68	60	57	51	51	54	43
	220	792	59	61	56	53	48	47	44	37	63	69	61	58	52	53	56	45
	290	1044	62	63	57	55	49	49	46	40	65	71	62	60	54	55	58	48
360	1296	64	65	58	57	51	51	48	42	67	73	63	62	55	57	60	49	
D16	30	108	46	55	50	36	38	34	31	21	51	64	62	44	47	43	43	36
	35	126	48	56	51	38	39	35	32	23	53	66	63	46	48	44	44	37
	80	288	57	61	56	44	43	41	38	30	62	71	67	52	52	50	50	44
	100	360	60	63	57	46	44	43	39	31	65	73	68	54	53	52	51	46
	120	432	62	64	58	47	45	44	40	33	67	74	69	55	54	53	52	47
	160	576	65	66	59	49	47	47	42	35	70	76	71	57	56	56	54	49
195	702	67	67	60	51	48	48	44	37	72	77	72	59	57	57	56	51	

Case-radiated Noise

Case-radiated noise calculation procedure

f_m	63	125	250	500	1000	2000	4000	8000
L_{W2}	43	38	42	39	39	39	32	27
Fume hood cladding	4	4	4	4	4	4	4	4
Sound power level to room	39	34	38	35	35	35	28	23
Room attenuation	5	5	4	4	3	3	3	3
A-weighting	-26	-16	-9	-3	0	1	1	-1
Corrected level	8	13	25	28	32	33	26	19

Sound pressure level of case-radiated noise $L_{pA2} = 37 \text{ dB(A)}$

Result: Note the above deviates from the room correction on page 6, here other values have been assumed. The result lies, however within that required.

Case-radiated Noise																		
Differential pressure sensor	\dot{V} l/s m ³ /h		$\Delta p_g = 200 \text{ Pa}$								$\Delta p_g = 500 \text{ Pa}$							
			L_{W2} in dB								L_{W2} in dB							
			f_m in Hz								f_m in Hz							
			63	125	250	500	1000	2000	4000	8000	63	125	250	500	1000	2000	4000	8000
Differential pressure device																		
100	55	198	34	31	38	34	31	31	23	17	41	42	50	44	39	39	32	27
	65	234	35	32	39	35	33	32	24	19	43	43	50	45	41	40	34	29
	140	504	43	38	42	39	39	39	32	27	50	49	54	50	48	47	42	37
	180	648	46	40	43	40	42	42	35	30	53	51	55	51	50	50	45	40
	220	792	48	41	44	42	43	43	37	32	55	52	56	52	52	51	47	42
	290	1044	51	44	45	43	46	46	40	35	58	55	57	54	54	54	50	45
360	1296	53	45	46	44	48	48	42	37	60	56	58	55	56	56	52	47	
160	30	108	31	33	38	30	27	28	19	12	37	44	50	42	36	39	30	25
	35	126	32	33	38	30	28	30	21	13	38	45	51	43	37	40	32	27
	80	288	39	38	40	33	34	36	30	22	45	49	53	46	44	47	41	36
	100	360	41	39	41	34	36	38	32	24	47	50	54	47	45	49	44	38
	120	432	43	40	41	35	37	40	34	26	49	51	54	48	47	50	46	40
	160	576	46	41	42	36	39	42	38	29	52	52	55	49	49	53	49	43
195	702	47	42	42	37	40	44	40	32	53	53	55	49	50	54	51	45	
Venturi nozzle																		
D10	55	198	33	28	30	26	29	30	23	18	36	36	36	31	33	36	35	25
	65	234	34	29	31	27	30	31	24	19	37	37	37	32	34	37	36	27
	140	504	41	35	35	33	35	37	31	25	44	44	40	38	39	43	43	33
	180	648	43	38	36	34	36	40	33	28	46	46	42	39	41	46	45	35
	220	792	45	39	37	36	37	41	35	29	48	47	43	41	42	47	47	37
	290	1044	47	42	38	38	39	43	37	32	50	50	44	43	44	49	49	39
360	1296	49	43	40	39	41	45	39	33	52	51	45	44	45	51	51	41	
D16	30	108	31	33	32	19	28	28	22	13	36	43	43	27	37	37	34	28
	35	126	33	34	33	20	29	29	23	15	38	44	44	28	37	38	35	29
	80	288	42	39	37	27	33	35	29	21	47	49	49	35	42	44	41	36
	100	360	45	41	38	28	34	37	30	23	50	51	50	36	43	46	42	38
	120	432	47	42	39	30	35	39	32	25	52	52	51	38	44	48	43	39
	160	576	50	44	41	32	37	41	34	27	55	54	52	40	46	50	45	41
195	702	52	45	42	34	38	42	35	29	57	55	53	42	47	51	47	43	

Order details for TVLK

with differential pressure flow screen or flow grid

Specification text *

Circular VAV controller made of flame-retardant polypropylene (PPs) for variable volume flow systems and fume cupboards. For the flow rate control of extract air containing contaminated or aggressive materials since all components coming into contact with the air stream are made of plastic.

Ready-to-use controller consisting of mechanical and electronic control components. The controllers contain an averaging differential pressure sensor for flow rate measurement and a control damper.

Special characteristics:

- All components coming into contact with the extract air are made of chemically resistant flame-retardant polypropylene
- Length of the VAV controller 392 mm, with flange 400 mm
- Very close control accuracy for the flow rate settings, even in case of unfavourable aerodynamic configuration of duct-work
- Maintenance-friendly, removable differential pressure sensors. Incorrect re-assembly of sensors impossible to sensor shapes
- Factory set up of flow rate. This includes aerodynamic function test of each controller using a dedicated test rig

Differential pressure sensor with 3 mm measuring holes hence insensitive to dirt.

Control closed damper blade air leakage to EN 1751, class 3. Position of the control damper blade determined externally by means of slot on end of shaft extension.

System pressure range 80 to 1000 Pa.

Same connecting diameter on both ends: 250 mm.

Casing air leakage complies with EN 1751, class B.

Controller option with flange on both ends

Option with additional silencer CAK for the reduction of air-regenerated noise.

Materials:

The casing and control damper are made of polypropylene (PPs), flame-retardant (V0) to UL 94. Plain bearings and sensor tubes are made of polypropylene (PP).

Control components:

- LABCONTROL controller
- Variable flow rate control with electronic controller for fume cupboards and integrated network chip according to the LON standard
- Supply voltage 24 V AC
- Transmission of the actual and setpoint values as network variables
- Static differential pressure measurement
- Quick acting actuator
- Minimum and maximum flow rate can be measured and adjusted
- Two volt-free switches for setting the control modes

* Text for a basic construction, for control components, see the design programme or price list.

Order code

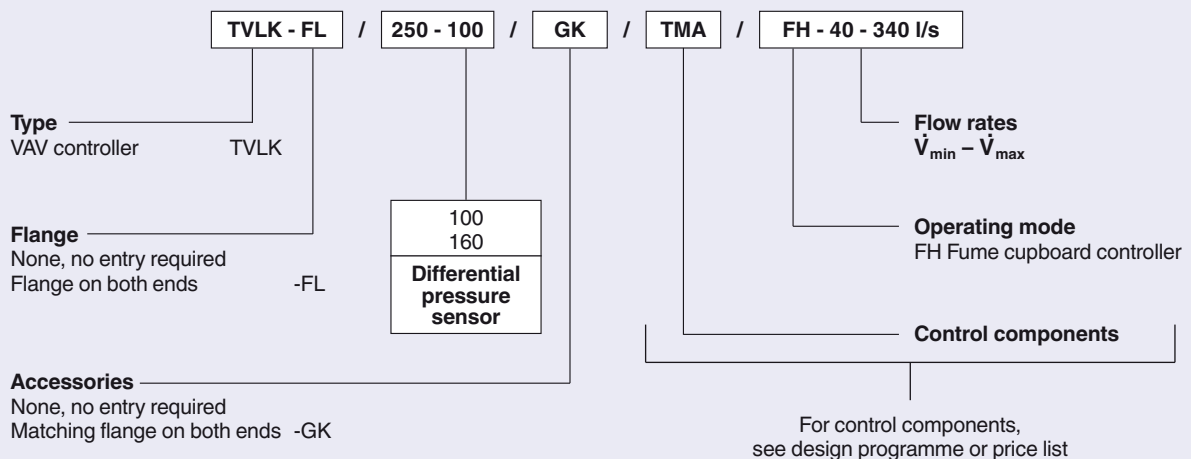

Order example

Make: TROX
 Type: TVLK - FL / 250 - 100 / GK / TMA / FH - 40 - 340 l/s

Order details for TVLK

with venturi nozzle

Specification text *

Circular VAV controller made of flame-retardant polypropylene (PPs) for variable volume flow systems and fume cupboards. For the flow rate control of extract air containing contaminated or aggressive materials since all components coming into contact with the air stream are made of plastic.

Ready-to-use controller consisting of mechanical and electronic control components. The controllers contain a venturi nozzle for flow rate measurement and a control damper.

Special characteristics:

- All components coming into contact with the extract air are made of sturdy, flame-retardant polypropylene
- Length of the VAV controller 392 mm, with flange 400 mm
- Very close control accuracy for the flow rate settings, even in case of unfavourable aerodynamic configuration of duct-work
- The venturi nozzle is removable for inspection and cleaning.
- Factory set up of flow rate. This includes aerodynamic function test of each controller using a dedicated test rig

Differential pressure sensor insensitive to dirt.

Control closed damper blade air leakage to EN 1751, class 3.

Position of the control damper blade determined externally by means of slot on end of shaft extension.

System pressure range 80 to 1000 Pa.

Same connecting diameter on both ends 250 mm.

Casing air leakage complies with EN 1751, class B.

Controller option with flange on both ends

Option with additional silencer CAK for the reduction of air-regenerated noise.

Materials:

The casing, venturi nozzle, and control damper are made of polypropylene (PPs), flame-retardant (V0) to UL 94. Plain bearings and sensor tubes are made of polypropylene (PP).

Control components:

- LABCONTROL controller
- Variable flow rate control with electronic controller for fume cupboards and integrated network chip according to the LON standard
- Supply voltage 24 V AC
- Transmission of the actual and setpoint values as network variables
- Static differential pressure measurement
- Quick acting actuator
- Minimum and maximum flow rate can be measured and adjusted
- Two volt-free switches for setting the control modes

* Text for a basic construction, for control components, see the design programme or price list.

Order code

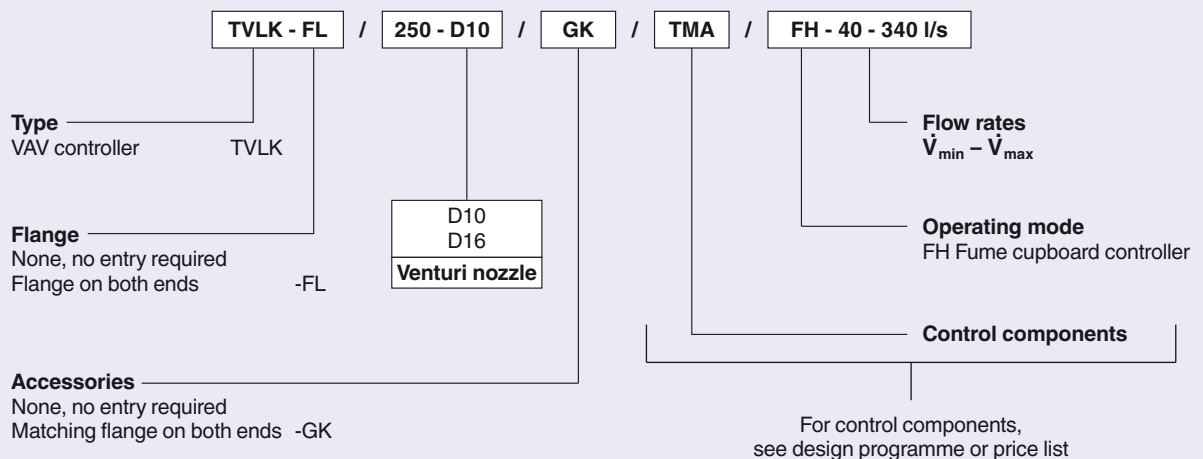

Order example

Make: TROX
 Type: TVLK - FL / 250 - D10 / GK / TMA / FH - 40 - 340 l/s

