

Dampers

- Type VFR
- for the adjustment of volume flow rates



TROX[®] TECHNIK

The art of handling air

Contents · Description

Description _____	2	Nomenclature · Quick selection _____	6
Type VFR – The System _____	3	Min/max changeover _____	7
Construction · Dimensions _____	4	Order Details _____	8
Leakage flow rate _____	5		

VFR with hand wheel



VFR with actuator



TROX type VFR dampers are used to adjust volume flow rates in air-conditioning and ventilation systems. They can be used in circular ventilation ducts with nominal sizes 80 to 250 and system pressures up to 1000 Pa. The damper blade is designed without a seal and with a circumferential gap between the case and blade tip of approximately 3 mm.

For the flow rate balancing the lockable hand wheel is steplessly adjustable over a scale range of 0 to 10. For site set up the required set point as a function of pressure difference and flow rate is indicated on a diagram label affixed to the outside casing of each VFR.

At the minimum setting (closed position 0) a system pressure dependent leakage flow rate occurs. Hence for low leakage shut-off of ducts according to EN 1751 type AK shut-off dampers must be used. See leaflet no. 5/10/EN/...

Min/max changeover is possible with VFR dampers equipped with an electric actuator. Easy retrofit of an actuator is also possible.

Further, current information on design and applications, as well as actuators available, can be found on our Website.

Our "air terminal units" design programme is also available on the Internet for the design and selection of our products.

Type VFR – The System

There are 3 configurations of the type VFR damper:

- Manual operation
- Actuator with potentiometers (E01, E02)
- Actuator with mechanical stops (M01, M02)

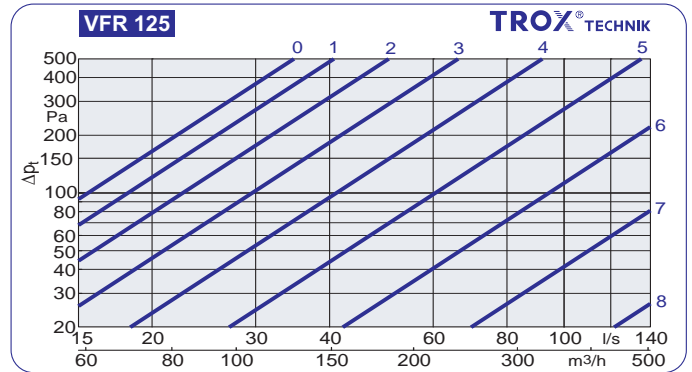

On each VFR, a diagram label is shown in order to determine the settings on site (example nominal size 125).

Type VFR – The System

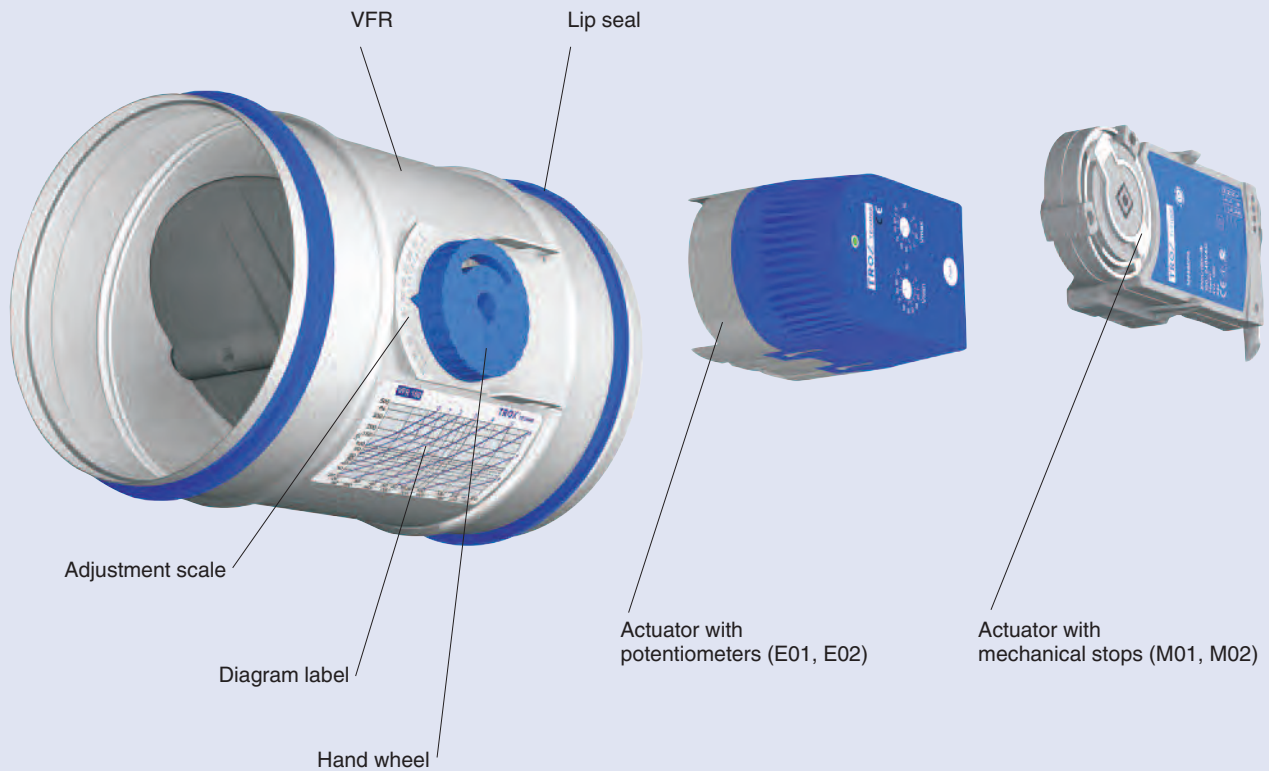

Construction · Dimensions

Characteristics

- For adjustment of flow rates and pressures
- Circular construction in 10 nominal sizes
- Manual adjustment
- Stepless adjustment of the damper blade from 0 to 10
- Maximum system pressure 1000 Pa
- Damper blade mechanism maintenance-free
- Operating temperature: 10 to 50 °C

Construction features

- Spigot connection with lip seal for circular connecting ducts according to EN 1506 or EN 13180
- Very good dimensional stability due to use of double beads in casing
- Casing air leakage complies with EN 1751, Class B

Actuator		Order code
Adjustment	Supply voltage	
Potentiometer	24 V	E01
	230 V AC	E02
Mechanical stops	24 V	M01
	230 V AC	M02

Adjustment with hand wheel

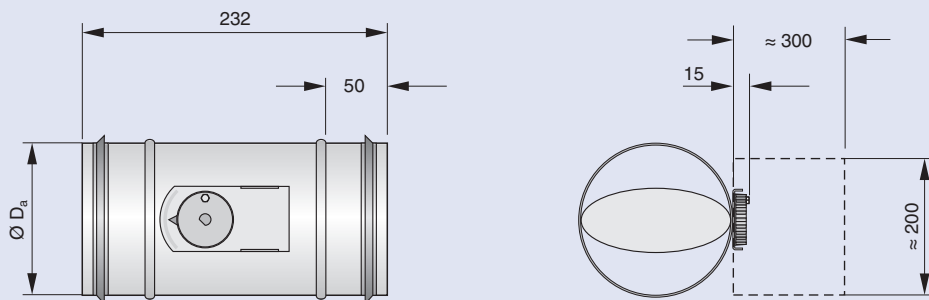

----- Keep clear to provide access for operation

Adjustment with potentiometers

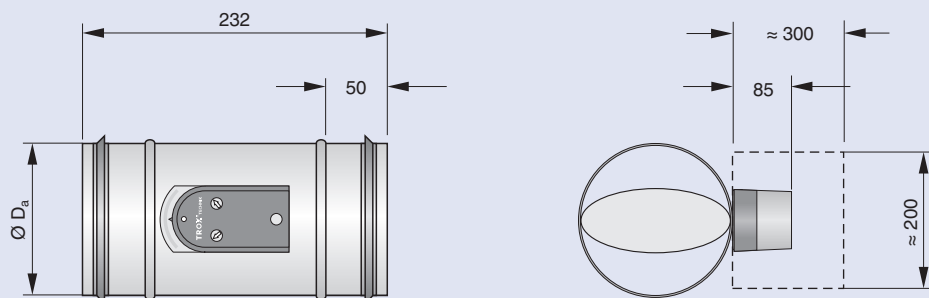

----- Keep clear to provide access to actuator

Construction · Dimensions · Leakage flow rate

Materials

- Casing in galvanised sheet steel
- Hand wheel, damper blade and bearings made of plastic flame retardant (V0) according to UL 94

Closed blade (0) leakage flow rate																				
Nominal size	80		100		125		140		150		160		180		200		224		250	
	Δp_t in Pa	l/s	m ³ /h	l/s	m ³ /h	l/s	m ³ /h	l/s	m ³ /h	l/s	m ³ /h	l/s	m ³ /h	l/s	m ³ /h	l/s	m ³ /h	l/s	m ³ /h	l/s
100	9	32	13	45	16	60	18	65	18	65	21	75	19	70	21	75	23	80	25	90
200	13	45	18	65	22	80	25	90	26	95	29	105	28	100	29	105	32	115	35	125
500	20	70	28	100	36	130	39	140	41	145	46	165	43	155	46	165	50	180	55	200

Adjustment with mechanical stops

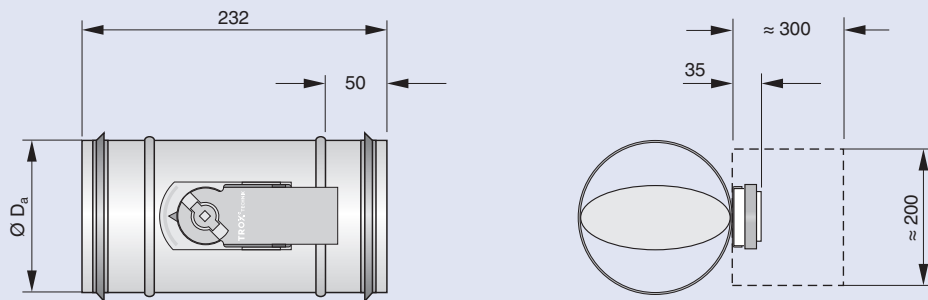

----- Keep clear to provide access to actuator

Dimensions in mm		Weight in kg	
Nominal size	ØD _a	Manual operation	With actuator
80	79	0,5	0,8
100	99	0,6	0,9
125	124	0,7	1,0
140	139	0,75	1,1
150	149	0,75	1,1

Dimensions in mm		Weight in kg	
Nominal size	ØD _a	Manual operation	With actuator
160	159	0,8	1,1
180	179	0,9	1,2
200	199	1,0	1,3
224	223	1,2	1,4
250	249	1,3	1,6

Nomenclature · Quick selection

Nomenclature

L_{PA} in dB(A) : A-weighted sound pressure level of air-regenerated noise, including a 5 dB system attenuation

\dot{V} in l/s or m³/h : Flow rate

Δp_t in Pa : Total differential pressure

All sound pressure levels are based on 20 μ Pa.
All noise levels determined in a reverberation chamber.

Sound pressure level L_{pA} in dB(A)										
Nominal size	Flow rate		Δp_t in Pa							
	l/s	m ³ /h	10	20	30	40	50	80	100	200
80	20	72	21	24	25	27	30	34	35	41
	30	108	28	30	31	33	36	39	40	45
	40	144	32	34	36	38	40	43	44	48
	50	180	36	38	39	41	44	46	47	51
100	30	108	25	27	28	31	33	36	38	44
	45	162	31	33	34	36	39	41	43	47
	60	216	36	38	39	41	43	45	47	50
	75	270	40	41	43	44	46	49	50	53
125	50	180	28	30	32	34	37	40	42	47
	70	252	34	36	37	39	42	45	46	51
	95	342	38	40	42	44	46	49	50	54
	120	432	42	44	45	47	49	52	53	57
140	60	216	27	29	30	33	36	39	41	46
	90	324	33	35	36	38	41	44	46	50
	120	432	37	39	41	43	45	48	49	54
	150	540	41	43	44	46	49	51	53	57
150	70	252	27	30	31	34	37	41	42	48
	105	378	33	35	37	39	42	45	47	52
	140	504	37	39	41	43	46	49	50	55
	170	612	40	42	44	46	49	52	53	57
160	80	288	29	31	33	35	38	41	43	48
	120	432	35	37	38	40	43	46	47	52
	155	558	40	42	43	45	47	50	51	55
	195	702	44	45	47	48	51	53	54	58
180	100	360	28	30	32	34	38	41	43	49
	150	540	34	36	38	40	43	46	48	53
	200	720	39	41	42	44	47	50	51	56
	250	900	43	45	46	48	51	53	55	59
200	125	450	28	31	33	36	39	43	45	51
	185	666	35	37	39	42	45	48	50	55
	245	882	40	42	44	46	49	52	54	59
	310	1116	44	46	48	50	53	56	57	62
224	155	558	28	31	32	35	39	42	44	49
	230	828	34	36	38	40	43	46	48	53
	310	1116	38	40	41	44	47	50	51	56
	385	1386	41	43	45	47	50	52	54	58
250	195	702	28	31	33	36	40	44	46	53
	290	1044	34	37	39	41	45	49	50	56
	385	1386	38	41	43	45	49	52	54	59
	485	1746	42	44	46	48	52	55	56	62

Actuator with potentiometers

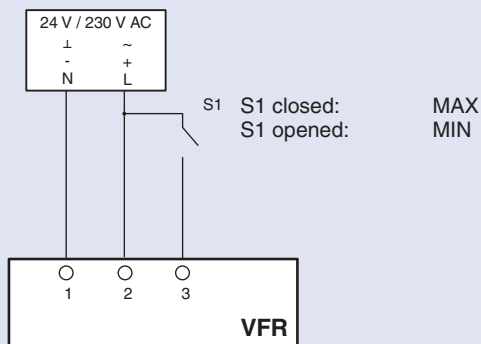

E01, E02

Actuator 24 V (E01)

Supply voltage: 24 V AC \pm 20 %, 50/60 Hz or 24 V DC \pm 10 %
 Power rating: max. 3 VA (for AC voltage) max. 3 W (for DC voltage)
 Control signal: 1- or 2-wire control
 Protection level: IP 42

Actuator 230 V AC (E02)

Supply voltage: 230 V AC \pm 20 %, 50/60 Hz
 Power rating: 3 VA
 Control signal: 1- or 2-wire control
 Protection level: IP 42

Functional testing

- Press service button
- Actuator turns towards MIN
- Actuator turns towards MAX
- Actuator returns to control mode

Indicator light provides functional information

- Permanently on: Position set
- Blinking once a second: Actuator operating
- Blinking twice a second: Actuator is jammed and stationary
- Off: No supply voltage

Actuator with mechanical stops

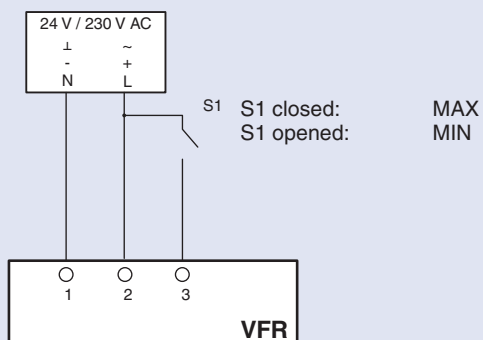
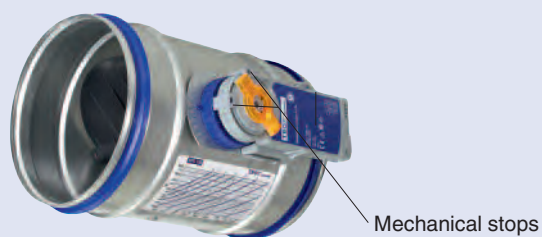

M01, M02

Actuator 24 V (M01)

Supply voltage: 24 V AC \pm 20 %, 50/60 Hz or 24 V DC \pm 10 %
 Power rating: max. 1 VA (for AC voltage) max. 0.5 W (for DC voltage)
 Protection level: IP 54

Actuator 230 V AC (M02)

Supply voltage: 100 V AC -15 % up to 240 V AC $+10$ %, 50/60 Hz
 Power rating: 3 VA
 Protection level: IP 54

Order Details



Specification text

Circular damper in 10 nominal sizes for the adjustment of flow rates in air-conditioning and ventilation systems, can be used with system pressures up to 1000 Pa. Consists of the casing with damper blade and the hand wheel for stepless adjustment.

Spigot connection with lip seal for circular connecting ducts according to EN 1506 or EN 13180. Casing air leakage complies with EN 1751, class B.

Materials:

Casing in galvanised sheet steel. Hand wheel, damper blade and bearings made of plastic flame retardant (V0) according to UL 94.

Order code

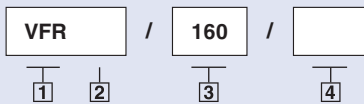

1 Type

2 Casing

Galvanised steel,
no entry required
-A2 Stainless steel

3 Nominal size

4 Actuator

Basic construction (manual setting), no entry required
E01 24 V, with potentiometers
E02 230 V AC, with potentiometers
M01 24 V, with mechanical stops
M02 230 V AC, with mechanical stops

Order example

Make: TROX
Type: VFR / 160